



coop FIS NORDIC WORLD  
SKI CHAMPIONSHIPS  
**TRONDHEIM  
2025**

Presented by  storEnso



FIS NORDIC WORLD  
SKI CHAMPIONSHIPS

# TRONDHEIM 2025

26<sup>TH</sup> FEBRUARY—9<sup>TH</sup> MARCH

OFFICIAL TEAM INVITATION

## Table of Contents

<b>1. Welcome</b> .....	<b>4</b>
<b>1.1. Welcome from the LOC</b> .....	<b>4</b>
<b>2. Contacts and useful links</b> .....	<b>6</b>
<b>2.1 Organizational charts</b> .....	<b>6</b>
<b>2.2 Contact list LOC</b> .....	<b>7</b>
2.2.1 Management .....	7
2.2.2 Sports management.....	8
2.2.3 Event support/contact info .....	9
<b>2.3 FIS Officials</b> .....	<b>9</b>
<b>2.4 Useful links</b> .....	<b>11</b>
<b>3. Important Dates and Deadlines</b> .....	<b>12</b>
<b>4. Event Program</b> .....	<b>13</b>
<b>4.1 Detailed competition schedule*</b> .....	<b>13</b>
<b>4.2 Supporting program (Ceremony plan)</b> .....	<b>16</b>
<b>4.3 Race office</b> .....	<b>16</b>
<b>4.4 Training opportunities</b> .....	<b>17</b>
<b>4.5 Team Attache</b> .....	<b>17</b>
<b>5. Venues and Facilities</b> .....	<b>18</b>
<b>5.1 CC-arena</b> .....	<b>18</b>
<b>5.2 Cross-Country Courses'</b> .....	<b>19</b>
<b>5.3 Nordic Combined Courses'</b> .....	<b>22</b>
<b>5.4 Para Cross-Country courses</b> .....	<b>25</b>
<b>5.5 Ski testing areas</b> .....	<b>26</b>
<b>5.6 SJ-arena</b> .....	<b>27</b>
<b>5.7 Lift access and opening times</b> .....	<b>29</b>
<b>6. FIS World Championships Rules</b> .....	<b>30</b>
<b>7. Organizational Information</b> .....	<b>33</b>
<b>7.1 Accommodation and Meals</b> .....	<b>33</b>
7.1.1 Accommodation .....	33
7.1.2 FIS World Championship Rules overview.....	34
7.1.3 Meals arrangements .....	36
<b>7.2 Transport and parking</b> .....	<b>36</b>
7.2.1 Transportation .....	36
7.2.2 Parking information.....	37
7.2.3 Venue access information .....	37

<b>7.3 Team Captains Meeting.....</b>	<b>37</b>
<b>7.4 Wax Cabins and wax trucks for teams and SRS Industry .....</b>	<b>38</b>
<b>7.5 Accreditation and Course Access.....</b>	<b>39</b>
7.5.1 Accreditation.....	39
7.5.2 Course access.....	39
<b>7.6 Medical services .....</b>	<b>39</b>
7.6.1 Hospitals and emergency services.....	39
7.6.2 Pharmacies .....	40
7.6.3 Doctors’ meetings.....	40
7.6.4 Insurance .....	40
<b>7.7. Anti-Doping.....</b>	<b>40</b>
<b>7.8 Visa request and information .....</b>	<b>41</b>
<b>7.9 FIS Family Tickets.....</b>	<b>41</b>
<b>7.10 Other .....</b>	<b>41</b>
7.10.1 The use of radios.....	41
7.10.2 Useful numbers .....	42
7.10.3 Truck driving .....	42
7.10.4 Press conferences .....	42
<b>8 Sustainability .....</b>	<b>43</b>

# 1. Welcome

## 1.1. Welcome from the LOC

The organizing committee is delighted to invite all national ski associations to attend the competitions of Trondheim 2025 FIS Nordic World Ski Championship. The races will take place from the 26<sup>th</sup> of February to the 9<sup>th</sup> of March.

### **Dear athletes and teams from all over the world!**

A warm welcome to our most essential guests, being you competing athletes and your official teams. Trondheim, hosting the FIS Nordic World Ski Championships 2025, and the LOC are honored to host and serve you through the championship.

### **Sustainability for our future**

Our overall ambition for Trondheim 2025 is to be the most sustainable WSC ever. We live in a world where climate change is alarming. We are working hard to set a new standard being a role model for future championships to be even better than us – and better for our world.

Trondheim 2025 is the biggest sports event in Norway this decade, organized for the second time in our city, last time in 1997. With its 215.000 inhabitants Trondheim is the third biggest city in Norway. The city was founded in 997 by Viking King Olav Tryggvason, now erected on top of a pillar at the city square. This square will serve as the Medal Plaza during the championship in 2025.

Trondheim is a part of Trøndelag County. Trøndelag has a long and strong skiing tradition in Cross Country, Nordic Combined and Ski Jumping. Many, Norwegian skiing legends are raised here such as the most decorated winter Olympian ever, cross country skier Marit Bjørgen.

### **Value-based, sustainable activity**

Trondheim 2025 is a value-based organization founded on three core values; inclusive, future-orientated, and efficient. By including we have equal prize money for all disciplines. For the first time in the WSC history we will execute a para sprint on the competition program. And we are including manpower from different environments of our society.

Our future orientation has made us braver on collaborating on new concepts. These are the likes of environmental-friendly snow production, eco-friendly transportation, and activity programs for everyone all over Norway. These are examples of how we communicate and act on how we govern our organization on reaching our main goals. We are also eager to show the world that it is possible to hold a World Championship at a facility built for everyday life.

We know you have been eagerly preparing for this championship over a long

period. By respect and awareness of how much it means to you as an athlete to perform at your very best, we will prepare for fulfilling your needs and service professionally by our hearts. We believe in dialogue where clarified expectations are vital to prepare our best service for you.

We really look forward to welcoming you to Trondheim 2025. We wish you all the best for your pre-WSC-season and look forward to seeing you in February 2025. To compete for a nation is an honor, we will serve you proudly as deserved.

**Welcome to Trondheim 2025!**

**Åge Skinstad**  
**CEO of the LOC Trondheim 2025**

## 2. Contacts and useful links

### 2.1 Organizational charts

#### Overview

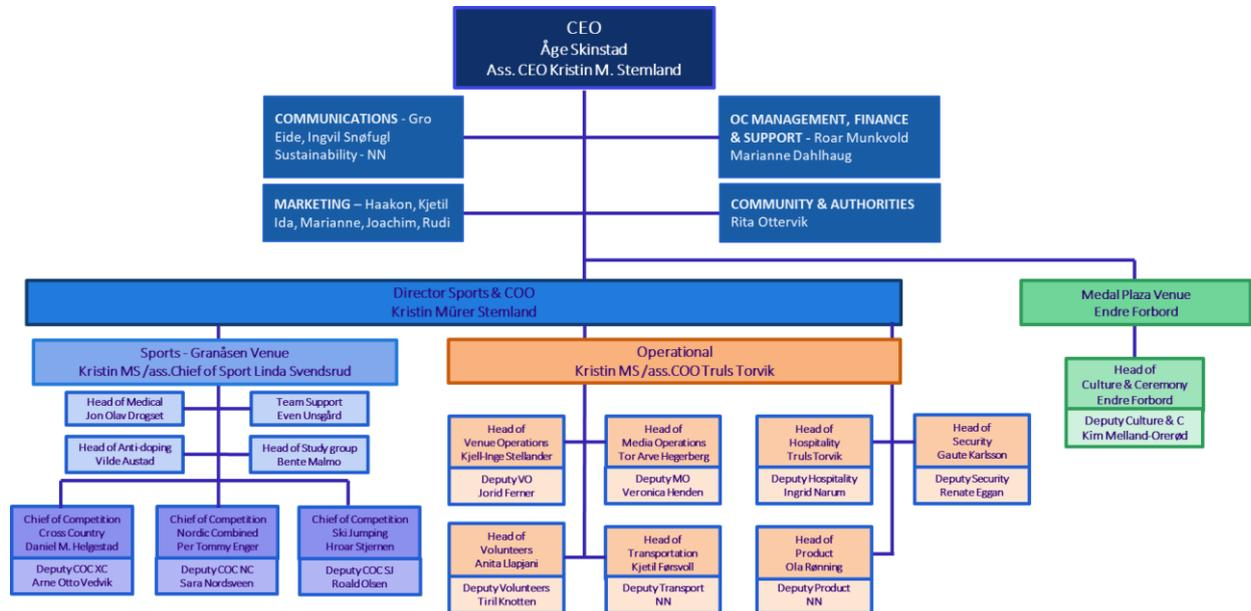

#### Sport

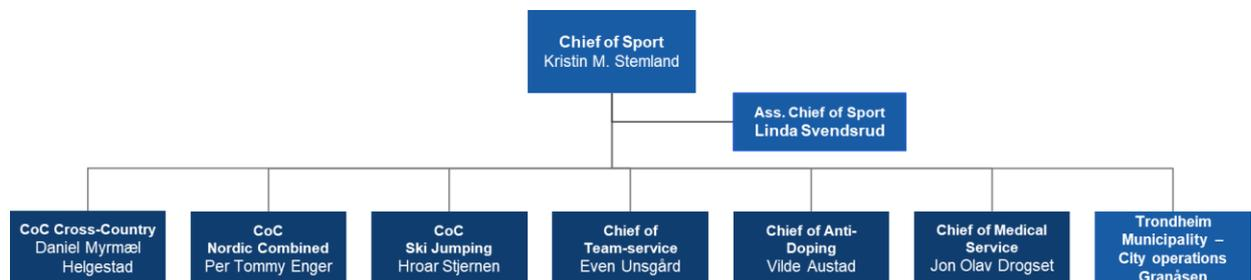

#### Cross-Country

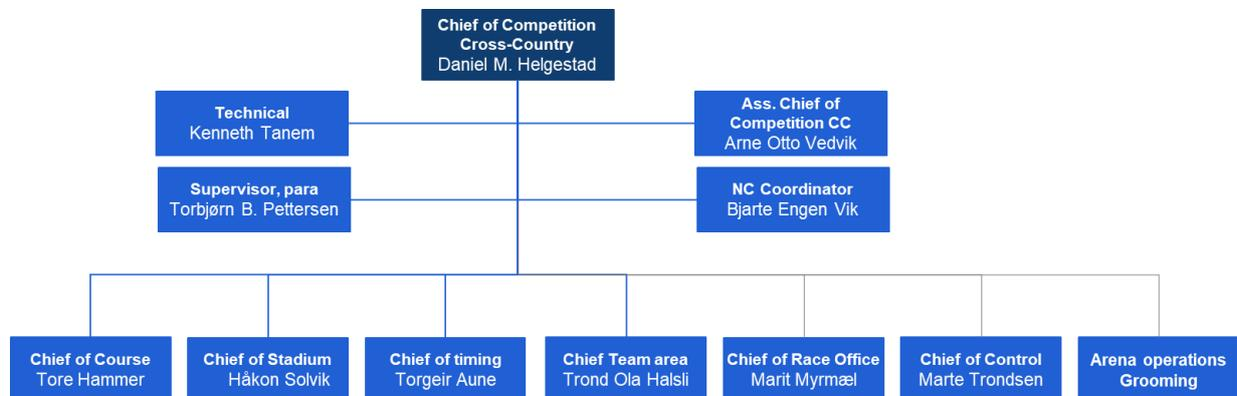

## Ski Jumping

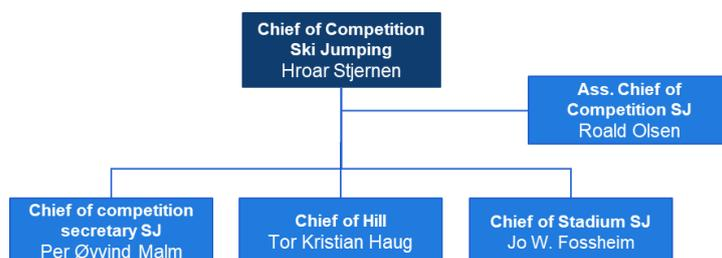

## Nordic Combined

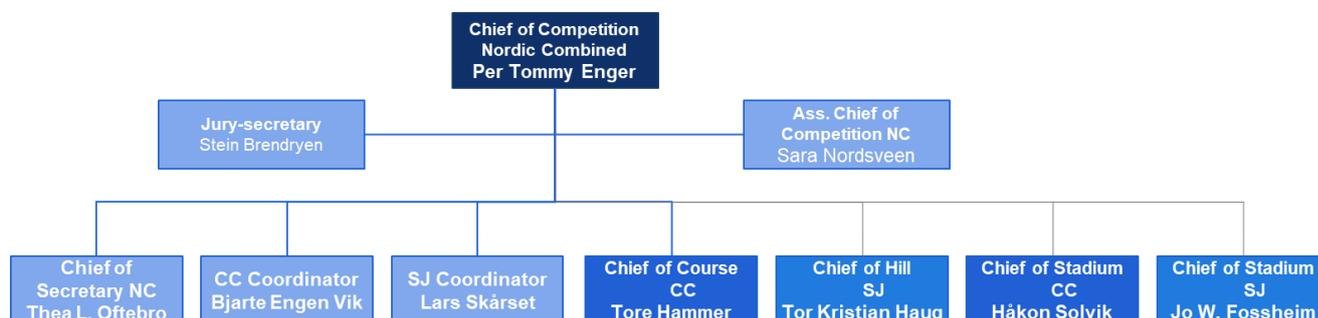

## 2.2 Contact list LOC

### 2.2.1 Management

Function	Name	Contact info
<b>CEO Trondheim 2025</b>	Åge Skinstad	t: +47 480 58 057 e: Age.skinstad@trondheim2025.no
<b>Chief Operating Officer (COO)</b>	Kristin Mürer Stemland	t: +47 930 34 542 e: kristin.m.stemland@trondheim2025.no
<b>Chief Financial Officer (CFO)</b>	Roar Munkvold	t: +47 916 61 563 e: roar.munkvold@trondheim2025.no
<b>Chief Marketing Officer (CMO)</b>	Haakon André Elveslett Jensen	t: +47 951 03 981 e: haakon.jensen@trondheim2025.no
<b>Chief Communication Officer (CCO)</b>	Gro Eide	t: +47 900 29 009 e: gro.eide@trondheim2025.no
<b>Chief Community &amp; Authorities Officer (CCAO)</b>	Rita Ottervik	t: +47 952 63 011 e: rita.ottervik@trondheim2025.no
<b>Chief of Security</b>	Gaute Karlsson	t: +47 452 88 874 e: gaute.karlsson@trondheim2025.no
<b>Chief of Transport</b>	Kjetil Førsvoll	t: +47 918 85 599 e: kjetil.forsvoll@trondheim2025.no

<b>Chief of Hospitality</b>	Truls Torvik	t: +47 951 42 086 e: truls.torvik@trondheim2025.no
<b>Ass. Chief of Hospitality</b>	Ingrid Narum	t: +47 926 01 421 e: ingrid.narum@trondheim2025.no
<b>Chief of Sustainability</b>	Ola Rønning	t: +47 977 29 343 e: ola.ronning@trondheim2025.no
<b>Chief of Culture and Ceremony</b>	Endre Forbord	t: +47 484 89 140 e: endre.forbord@trondheim2025.no
<b>Chief of Ceremony</b>	Kim Melland-Orerød	t: +47 458 44 041 e: kim.orerod@trondheim2025.no
<b>Chief of Volunteers</b>	Anita Llapjani	t: +47 404 97 350 e: anita.llapjani@trondheim2025.no
<b>Chief of Media Operations</b>	Tor Arve Hegerberg	t: +47 924 20 959 e: tor.arve.hegerberg@trondheim2025.no
<b>Chief of Technical service</b>	Kenneth Tanem	t: +47 930 39 902 e: kenneth.tanem@trondheim2025.no
<b>Chief of Arena Operation</b>	Kjell Stellander	t: +47 916 72 882 e: kjell.stellander@trondheim2025.no

## 2.2.2 Sports management

<b>Function</b>	<b>Name</b>	<b>Contact info</b>
<b>Chief of Sport</b>	Kristin M. Stemland	t: +47 930 34 542 e: kristin.m.stemland@trondheim2025.no
<b>Ass. Chief of Sport</b>	Linda Svendsrud	t: +47 959 49 294 e: linda.svendsrud@trondheim2025.no
<b>Chief of Competition CC</b>	Daniel Myrmæl Helgestad	t: +47 950 21 058 e: daniel.helgestad@trondheim2025.no
<b>Ass Chief of Competition CC</b>	Arne Otto Vedvik	t: +47 900 67 657 e: arne.vedvik@trondheim2025.no
<b>Chief of Course</b>	Tore Hammer	t: +47 913 10 057 e: tore.hammer@trondheim2025.no
<b>Chief of Stadium CC</b>	Håkon Solvik	t: +47 926 01 677 e: hakon.solvik@trondheim2025.no
<b>Chief of Team Area CC</b>	Trond Ola Halsli	t: +47 915 10 742 e: trond.halsli@trondheim2025.no
<b>Chief of Control</b>	Marte Trondsen	t: +47 971 55 330 e: marte.trondsen@trondheim2025.no
<b>Chief of Timing</b>	Torgeir Aune	t: +47 993 89 829 e: torgeirra@gmail.com
<b>Chief of Competition SJ</b>	Hroar Stjernen	t: +47 909 81 878 e: hroar@koment.no
<b>Ass Chief of Competition SJ</b>	Roald Olsen	t: +47 990 02 879 e: roald.olsen@trondheim2025.no
<b>Chief of Hill</b>	Tor Kristian Haug	t: +47 959 30 381 e: tor.kristian.haug@smn.no
<b>Chief of Stadium SJ</b>	Jo W. Fossheim	t: +47 918 11 326 e: jo.fossheim@trondheim2025.no
<b>Chief of Secretary SJ</b>	Per Øyvind Malm	t: +47 901 72 398 e: per.malm@trondheim2025.no

<b>Chief of Competition NC</b>	Per Tommy Enger	t: +47 404 00 105 e: per.tommy.enger@trondheim2025.no
<b>Ass Chief of Competition NC</b>	Sara Nordsveen	t: +47 954 96 548 e: sara.nordsveen@trondheim2025.no
<b>Chief of Secretary NC</b>	Thea Oftebro	t: +47 952 18 590 e: thea.oftebro@trondheim2025.no
<b>Jury-secretary NC</b>	Stein Brendryen	t: +47 904 19 165 e: stein.brendryen@trondheim2025.no
<b>CC Coordinator NC</b>	Bjarte Engen Vik	t: +47 992 62 152 e: bjarte.vik@trondheim2025.no

### 2.2.3 Event support/contact info

Function	Name	Contact info
<b>Sport</b>	-	e: sport@trondheim2025.no
<b>Team Service</b>	Even Unsgård	t: +47 902 80 114 e: even.unsgard@trondheim2025.no
<b>Media</b>	-	e: media@trondheim2025.no
<b>Accommodation</b>	Bente Laugen	t: +47 480 74 467 e: accommodation@trondheim2025.no
<b>Accreditation</b>	Sølvi Stokkeland	e: accreditation@trondheim2025.no e: solvi.stokkeland@trondheim2025.no
<b>Transportation and parking</b>	-	t: +47 48058057 e: transport@trondheim2025.no
<b>Medical service</b>	Jon Olav Drogset	t: +47 920 64 873 e: jon.olav.drogset@trondheim2025.no
<b>Anti-Doping</b>	Vilde Austad	t: +47 901 25 341 e: vilde.austad@trondheim2025.no
<b>Finances</b>	Silje Solbakken	t: +47 476 20 321 e: finance@trondheim2025.no
<b>Weather service</b>	Kristian Gislefoss	t: +47 402 21 313 e: kristiang@met.no
<b>IT Help desk</b>	TBD	TBD
<b>Radio Equipment</b>	Ronny Kristiansen	e: ronny.kristiansen@trondheim2025.no
<b>HSE</b>	Renate Eggen	t: +47 917 19 332 e: renate.eggan@trondheim2025.no

## 2.3 FIS Officials

FIS Management	
FIS President	Johan Eliasch, FIS
Secretary General	Michel Vion, FIS
Event and Sport Manager	Sandra Spitz, FIS
Sustainability	Susanna Sieff, FIS

## Cross-Country

Race Director	Michal Lamplot, FIS
Race Director Assistant	Simon Caprini, FIS
WC Coordinator	Doris Kallen, FIS
Media Coordinator	Synne Dyrhaug, FIS
Technical Delegate 1st week	Anna Rosa, ITA
Assistant Technical Delegate 1st week	Thomas Unterfrauner, AUT
Technical Delegate 2nd week	Thomas Unterfrauner, AUT
Assistant Technical Delegate 2nd week	Anna Rosa, ITA
Jury Member	Seraina Mischol, SUI
Jury Member	Martins Niklass, LAT
Equipment Controller	TBD

## Ski Jumping

Race Director Men	Sandro Pertile, FIS
Assistant Race Director Men	Borek Sedlak, FIS
Race Director Women	Chika Yoshida, FIS
Assistant Race Director Women	Miran Tepes, FIS
Media Coordinator	Horst Nilgen, FIS
Technical Delegate	Aljosa Dolhar, SLO
Assistant Technical Delegate	Andi Bauer, GER
Assistant Technical Delegate	Suzanne Tahk, EST
Equipment Control Men	Christian Kathol, FIS
Equipment Control Women	Agnieszka Baczkowska, FIS
Judge	Ole Walseth, NOR
Judge	Parma Jiri, CZE
Judge	Olaf Beyer, GER
Judge	Sandro Sambugaro, ITA
Judge	Fabrice Piazzini, ITA
Judge	Steve Sydow, USA

## Nordic Combined

Race Director	Lasse Ottesen, FIS
Assistant Race Director	Jan Rune Grave, FIS
Media Coordinator	Sophie Hargesheimer, FIS
Technical Delegate	Matija Stegnar, SLO
Assistant Technical Delegate	Jana Koziskova, CZE

Equipment Control Men	Guntram Kraus, FIS
Equipment Control Women	Kerstin Löscher, FIS

Para Cross-Country	
Race Director	Georg Zipfel
Para Nordic Coordinator	Elke Gundermann
Technical Delegate	TBD
Assistant Technical Delegate	TBD
Adaptive Equipment Controller (Classification)	TBD

Medical/Anti-Doping	
Medical Supervisor	TBD
Anti-Doping Coordinator	Rasmus Damsgaard, FIS
Anti-Doping Coordinator	Vanda Wallace-Jones, FIS

## 2.4 Useful links

Links	
Website FIS	<a href="https://www.fis-ski.com/">https://www.fis-ski.com/</a>
Website Trondheim 2025	<a href="https://trondheim2025.no/en/">https://trondheim2025.no/en/</a>
Instagram	<a href="http://instagram.com/trondheim2025">http://instagram.com/trondheim2025</a>
LinkedIn	<a href="https://www.linkedin.com/company/trondheim2025/">https://www.linkedin.com/company/trondheim2025/</a>
Facebook	<a href="http://facebook.com/trondheim2025">http://facebook.com/trondheim2025</a>
Hashtag	#trondheim2025

### 3. Important Dates and Deadlines

Table of time limits for entries and other important information.

Article	What	When	Details	Who
	FIS Entry System For Para: FPDMS	16 August 2024	System opens for Preliminary Team Entries	NSAs
	Accreditation	15 September 2024	Open the registration system	NSAs
	Team attaché	15 September 2024	Deadline for submitting requests for a team attaché. See point 4.4 in this document.	NSAs
12.3	FIS Entry System For Para: FPDMS	31 October 2024	System opens for Provisional Team Selection	NSAs
	Extra Wax cabins	31 October 2024	Registration of extra wax cabins	NSAs and SRS
	Response Accommodation	15 November 2024	Teams have gotten feedback from LOC on Accommodation	LOC
12.4.1	FIS Entry System For Para: FPDMS	5 February 2025	System opens for Final Team Selection/ Final Team Selection for Para	NSAs
12.4.2	FIS Entry System	24 hours after the last FIS World Cup event of the respective discipline before the FIS World Championships (10.02. NC, 17.2 CC, 17.02 SJM 24.02. SJW)	Final Team Selection (not applicable for Para)	NSAs
12.5	FIS Entry System	In principle 2 hours before the respective TCM (according to respective ICRs)	Definite Competition Entry	NSAs/Team Captain
	Visa	ASAP	Check the Visa information under point 7.8 in this document	NSAs
	Radio	ASAP	Deadline for Frequency Application see point 7.10.1 in this document	NSAs

## 4. Event Program

### 4.1 Detailed competition schedule\*

Time	Discipline	Race format	Arena
<b>Tue.25</b>			
12:30 - 14:30	CC	Official training Qualification race	CC-arena
17:30 - 19:00	CC	TCM Qualification race/Info meeting CC	Scandic Lerkendal
19:00 - 20:00	NC	Info meeting women NH	Scandic Lerkendal
20:00 - 21:00	SJ	Info meeting women NH	Scandic Lerkendal
<b>Wed.26</b>			
10:00 - 12:00	CC	Official training Sprint	CC-arena
10:00 - 12:00	NC	Official training_1 women NH (x3)	SJ-arena - NH
<b>13:30 - 14:20</b>	<b>CC</b>	<b>Qualification race 7,5 km classic - women</b>	<b>CC-arena</b>
14:00 - 15:50	SJ	Official training_1 women NH (x3)	SJ-arena - NH
<b>15:30 - 16:40</b>	<b>CC</b>	<b>Qualification race 7,5 km classic - men</b>	<b>CC-arena</b>
16:00 - 16:15	SJ	TCM - Women	Granåsen
17:30 - 18:30	NC	Official training 5 km mass start	CC-arena
18:00 - 19:00	CC	TCM Sprint	Granåsen
19:00 - 19:30	NC	Info meeting men NH	Scandic
19:30 - 19:45	NC	TCM - Mass start 5 km	Scandic Lerkendal
<b>Thu. 27</b>			
<b>10:00 - 11:15</b>	<b>CC</b>	<b>Sprint qualification free - women/men</b>	<b>CC-arena</b>
10:00 - 12:00	NC	Official training (x3)	SJ-arena NH
<b>12:30 - 14:15</b>	<b>CC</b>	<b>Sprint finals free - women/men</b>	<b>CC-arena</b>
<b>15:00 - 15:20</b>	<b>NC</b>	<b>Mass start 5 km - women</b>	<b>CC-arena</b>
16:00 - 17:00	NC	Official training Mixed team	CC-arena
17:45	SJ	Trial round individual NH women	SJ-arena NH
<b>18:20 - 18:50</b>	<b>NC</b>	<b>Competition individual NH women</b>	<b>SJ-arena NH</b>
20:00 - 20:30	NC	TCM - Mixed team	Scandic Lerkendal
19:30 - 20:10	SJ	Trial round individual NH women	SJ-arena NH
20:30 - 21:30	SJ	Qualification individual NH women	SJ-arena NH
<b>Fri. 28</b>			
11:00 - 11:30	SJ	Info meeting men NH	Scandic Lerkendal
11:00	NC	Trial round mixed team NH	SJ-arena NH
11:30 - 13:30	CC	Training Skiathlon	CC-arena
<b>12:00 - 12:50</b>	<b>NC</b>	<b>Competition mixed team NH (w m m w)</b>	<b>SJ-arena NH</b>
13:00	SJ	Trial round individual NH women	SJ-arena NH
<b>14:00 - 15:45</b>	<b>SJ</b>	<b>Competition individual NH women</b>	<b>SJ-arena NH</b>
14:30 - 15:30	NC	Official training Compact men	CC-arena
16:15 - 16:30	SJ	TCM Team Women NH	Granåsen
<b>16:15 - 17:00</b>	<b>NC</b>	<b>Mixed team Cross-Country - 5, 2.5, 2.5, 5 km</b>	<b>CC-arena</b>
17:00 - 20:00	SJ	Official training men_1 (x3)	SJ-arena NH

17:30 - 17:45	NC	TCM - Compact men	Granåsen
18:00 - 19:00	CC	TCM Skiathlon men	Granåsen
20:30 - 20:45	SJ	TCM Individual men NH	Granåsen
<b>Sat. 1</b>			
11:00	NC	Trial round NC individual NH men	SJ-arena NH
<b>12:00 - 12:50</b>	<b>NC</b>	<b>Competition individual NH men</b>	<b>SJ-arena NH</b>
<b>14:00 - 15:00</b>	<b>CC</b>	<b>Skiathlon 20 km (10 + 10) C/F - men</b>	<b>CC-arena</b>
<b>16:15 - 16:45</b>	<b>NC</b>	<b>Compact 7,5 km men</b>	<b>CC-arena</b>
16:15	SJ	Trial team NH women	SJ-arena NH
16:45 - 17:00	NC	TCM - Gundersen women	Granåsen
<b>17:15 - 18:50</b>	<b>SJ</b>	<b>Competition team NH women</b>	<b>SJ-arena NH</b>
TBC	NC	Official training Gundersen women	CC-arena
18:00 - 19:00	CC	TCM Skiathlon women	Granåsen
19:30	SJ	Trial round individual NH men	SJ-arena NH
20:30 - 21:30	SJ	Qualification individual NH men	SJ-arena NH
<b>Sun. 2</b>			
11:00	NC	Trial round NC individual NH women	SJ-arena NH
<b>12:00 - 12:30</b>	<b>NC</b>	<b>Competition individual NH women</b>	<b>SJ-arena NH</b>
<b>14:00 - 15:00</b>	<b>CC</b>	<b>Skiathlon 20 km (10 + 10) C/F - women</b>	<b>CC-arena</b>
<b>16:15 - 16:45</b>	<b>NC</b>	<b>Gundersen 5 km women</b>	<b>CC-arena</b>
16:30	SJ	Trial round individual NH men	SJ-arena NH
<b>17:15 - 18:45</b>	<b>SJ</b>	<b>Competition individual NH men</b>	<b>SJ-arena NH</b>
<b>Mon. 3</b>			
10:00 - 12:00	CC	Training 10 km/Team sprint	CC-arena
14:00 - 15:30	PCC	Official training Sprint	CC-arena
18:00 - 19:00	CC/PCC	TCM Para Sprint/TCM 10 km	Granåsen
19:00 - 19:30	NC	Info meeting men	Scandic Lerkendal
<b>Tue. 4</b>			
08:30 - 08:50	SJ	Info meeting women LH	Scandic Lerkendal
09:00 - 09:20	SJ	Info meeting men LH	Scandic Lerkendal
<b>10:00 - 11:00</b>	<b>PCC</b>	<b>Qualification Para Sprint classic - women/men</b>	<b>CC-arena</b>
10:00 - 11:15	NC	Official Training_1 (2x)	SJ-arena LH
<b>13:00 - 14:30</b>	<b>CC</b>	<b>Individual 10 km classic - men</b>	<b>CC-arena</b>
13:30 - 16:00	SJ	Official Training_1 (3x) women	SJ-arena LH
<b>15:30 - 17:00</b>	<b>CC</b>	<b>Individual 10 km classic - women</b>	<b>CC-arena</b>
17:00 - 19:30	SJ	Official Training_1 (3x) men	SJ-arena LH
18:00 - 19:00	CC	TCM - Team Sprint/Para Finals	Granåsen
20:00 - 20:30	SJ	TCM Mixed team	Granåsen
<b>Wed. 5</b>			
<b>08:45 - 09:45</b>	<b>PCC</b>	<b>Semifinals Para Sprint Classic - women/men</b>	<b>CC-arena</b>
<b>11:00 - 12:00</b>	<b>CC</b>	<b>Qualification team sprint classic - women/men</b>	<b>CC-arena</b>
11:00 - 12:30	NC	Official Training_1 (2x) men	SJ-arena LH
<b>12:20 - 13:00</b>	<b>PCC</b>	<b>Finals Para Sprint Classic - women/men</b>	<b>CC-arena</b>

13:00 – 13:15	NC	TCM - Team men	Granåsen
<b>14:30 - 15:30</b>	<b>CC</b>	<b>Finals Team Sprint classic - women/men</b>	<b>CC-arena</b>
15:15	SJ	Trial Mixed team LH	SJ-arena LH
<b>16:15 - 18:00</b>	<b>SJ</b>	<b>Competition Mixed team LH</b>	<b>SJ-arena LH</b>
17:00 - 19:00	CC	Training Relay	CC-arena
17:00 - 19:00	NC	Official Training Team men	CC-arena
18:30 - 18:50	SJ	TCM - Ind. Women	Granåsen
19:00 - 19:30	SJ	TCM - Team men and Individual men	Granåsen
19:30 - 20:00	CC	TCM Relay men	Granåsen
<b>Thu. 6</b>			
10:30	NC	Trial round NC Team LH - men	SJ-arena
<b>11:30 - 12:20</b>	<b>NC</b>	<b>Competition Team LH - men</b>	<b>SJ-arena LH</b>
<b>13:00 - 14:30</b>	<b>CC</b>	<b>Relay 4x7,5 km C/F - men</b>	<b>CC-arena</b>
<b>15:50 - 16:30</b>	<b>NC</b>	<b>Team men - 4 x 5 km</b>	<b>CC-arena</b>
16:00	SJ	Trial round Team LH men	SJ-arena LH
<b>17:00 - 18:50</b>	<b>SJ</b>	<b>Competition Team LH men</b>	<b>SJ-arena LH</b>
18:00 - 19:00	CC	TCM Relay women	Granåsen
19:30 - 20:00	SJ	Official training_2 (x1) /Trial round ind. LH women	SJ-arena LH
20:30 - 21:30	SJ	Qualification individual LH women	SJ-arena LH
<b>Fri. 7</b>			
10:00 - 11:30	NC	Official training_1 (x2) men	SJ-arena LH
12:00 - 13:00	SJ	Official training_2 (x1) / Trial Individual LH - men	SJ-arena LH
14:00 - 15:00	SJ	Qualification Individual LH - men	SJ-arena LH
<b>15:15 - 16:45</b>	<b>CC</b>	<b>Relay 4x7,5 km C/F - women</b>	<b>CC-arena</b>
16:00	SJ	Trial Individual LH - women	SJ-arena LH
<b>17:15 - 18:50</b>	<b>SJ</b>	<b>Competition Individual LH - women</b>	<b>SJ-arena LH</b>
17:30 - 19:30	CC	Training 50 km	CC-arena
17:30 - 19:00	NC	Official training Gundersen men	CC-arena
19:00 - 19:30	NC	TCM Individual Gundersen LH men	Granåsen
20:00 - 21:00	CC	TCM 50 km men	Granåsen
<b>Sat. 8</b>			
08:30	NC	Trial round NC Individual LH - men	SJ-arena LH
<b>09:30 - 10:30</b>	<b>NC</b>	<b>Competition Individual LH - men</b>	<b>SJ-arena LH</b>
<b>11:30 - 14:00</b>	<b>CC</b>	<b>Mass start 50 km free - men</b>	<b>CC-arena</b>
<b>14:30 - 15:00</b>	<b>NC</b>	<b>Gundersen men - 10 km</b>	<b>CC-arena</b>
15:00	SJ	Trial round Individual LH men	SJ-arena LH
<b>16:00 - 18:00</b>	<b>SJ</b>	<b>Competition Individual LH men</b>	<b>SJ-arena LH</b>
18:00 - 19:00	CC	TCM 50 km women	Granåsen
<b>Sun. 9</b>			
<b>11:30 - 14:10</b>	<b>CC</b>	<b>Mass start 50 km free - women</b>	<b>CC-arena</b>

\* *Subject to changes. Final program will be published at <https://trondheim2025.no/en/>*

## 4.2 Supporting program (Ceremony plan)

Time	Discipline	Format	Arena
<b>Tue. 25</b>			
15 -18:00	All	Doctors meeting – seminar	Scandic Lerkendal
<b>Wed. 26</b>			
20:00	Ceremony	Opening ceremony	City Square
TBD	Concert	Invited guests	Nidarosdomen
<b>Thu. 27</b>			
20:00	Medal ceremony	Sprint women, Sprint men	City Square
<b>Fri. 28</b>			
20:00	Medal ceremony	NC women, SJ NH women, NC mixed team	City Square
<b>Sat. 1</b>			
20:00	Medal ceremony	Skiathlon men, NC ind. men	City Square
<b>Sun. 2</b>			
20:00	Medal ceremony	SJ team women, Skiathlon women, NC ind. women	City Square
<b>Mon. 3</b>			
TBD	Official Gala dinner	Invited guests	City of Trondheim
<b>Tue. 4</b>			
20:00	Medal ceremony	CC ind. 10 km men, CC ind. 10 km women, SJ NH men	City Square
<b>Wed. 5</b>			
20:00	Medal ceremony	CC team sprint men & women, Para, Mixed team SJ	City Square
<b>Thu. 6</b>			
20:00	Medal ceremony	CC Relay men, NC Team men	City Square
<b>Fri. 7</b>			
20:00	Medal ceremony	CC Relay women, SJ Team LH men	City Square
<b>Sat. 8</b>			
20:00	Medal ceremony	CC 50 km men, NC ind. men, SJ LH women, SJ LH men	City Square
<b>Sun. 9</b>			
14:30	Ceremony	CC 50 km women + Closing ceremony	CC-arena

## 4.3 Race office

Race Office Cross-Country will be inside the main arena building in the Cross-Country arena. Race Office Nordic Combined CC will be located just outside of the main entrance for the arena building Cross-Country.

In the Ski Jumping arena, race office for both Ski Jumping and Nordic Combined SJ are in the main SJ-arena building, second floor, outside the team Hospitality area (Café Ljøken).

The opening hours will be in connection with training and competition times. More details in the team guide that will be sent out before the event.

## 4.4 Training opportunities

### Cross-country training courses

At Skistua, there will be courses for training outside Granåsen arena. Skistua is approximately 20 minutes' drive from the team hotels.

### Indoor

We offer free training for teams in indoor training halls nearby the two team hotels. There you can, for example, play volleyball or floor ball.

### Fitness center

We offer free training for athletes in Fitness center nearby the two team hotels. For team officials/trainers and SRS it will cost 10 CHF per visit. It is a public training center, but between 10am-1pm it will be WSC teams' access only.

For transport to indoor training and training courses, transportation must be booked before latest 8pm the day before. The booking request for both transport and training hours will be at the service desk in the two team hotels. The transportation is free of charge.

## 4.5 Team Attache

We offer each nation a team attaché who will assist in arrival/departure and serve as a contact person for the team leader/team during the stay. They will also help with translation in case of language challenges. Larger nations can have up to 2 team attachés per nation to be distributed among their branches.

Requests for a team attaché must be submitted to [sport@trondheim2025.no](mailto:sport@trondheim2025.no). Deadline for submitting requests for a team attaché is 15<sup>th</sup> September 2024. (See Ch. 3)

# 5. Venues and Facilities

## 5.1 CC-arena

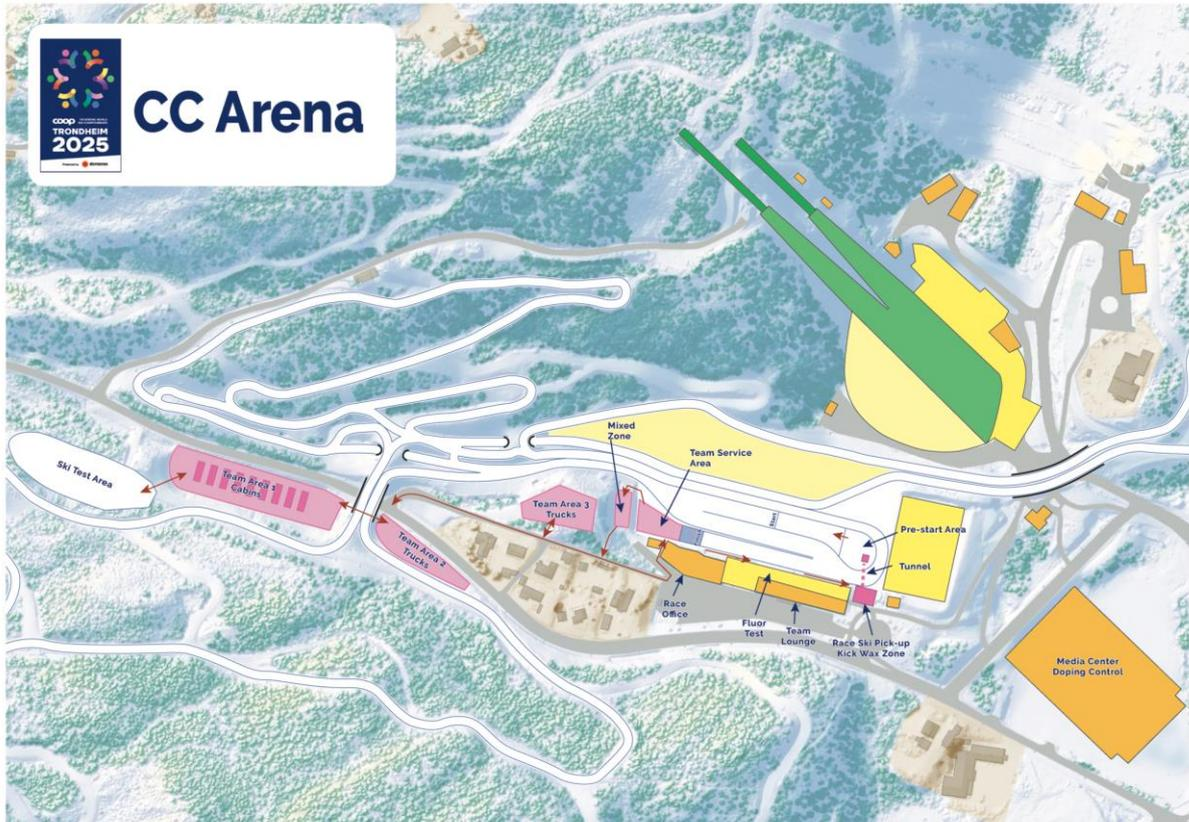

Cartography: eMap as (www.emap.no)

## 5.2 Cross-Country Courses'

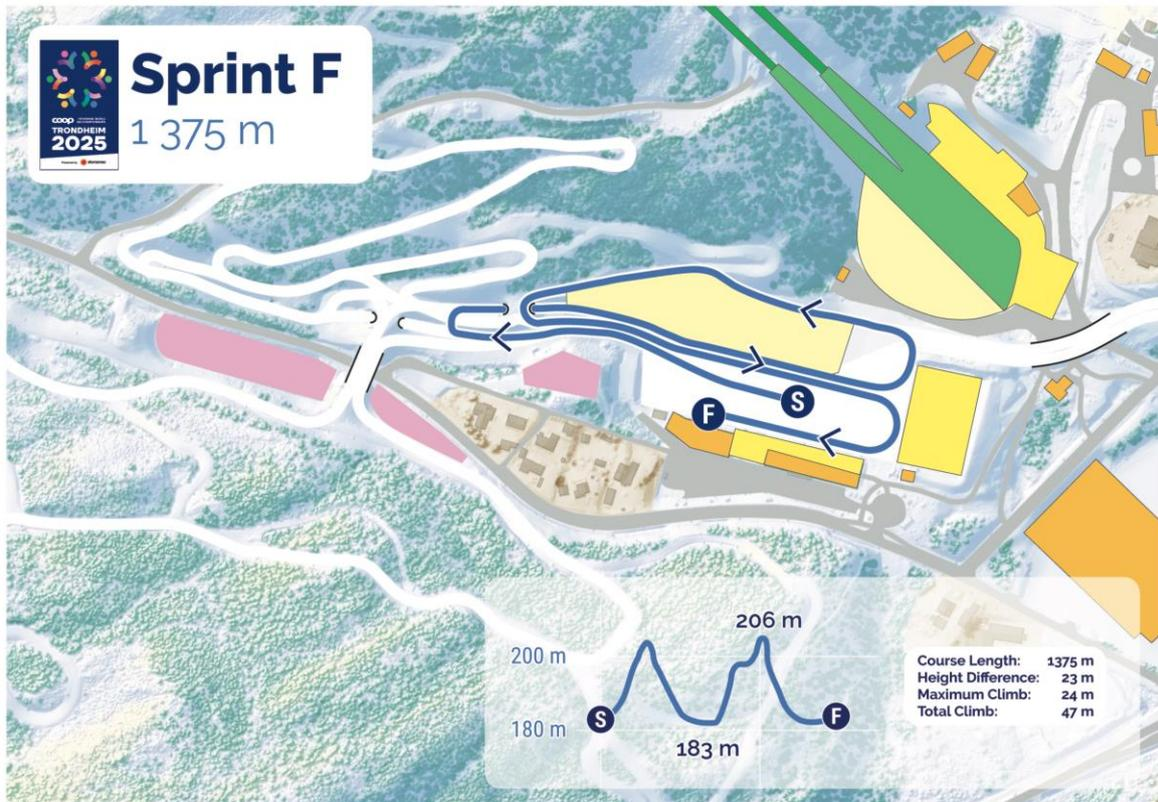

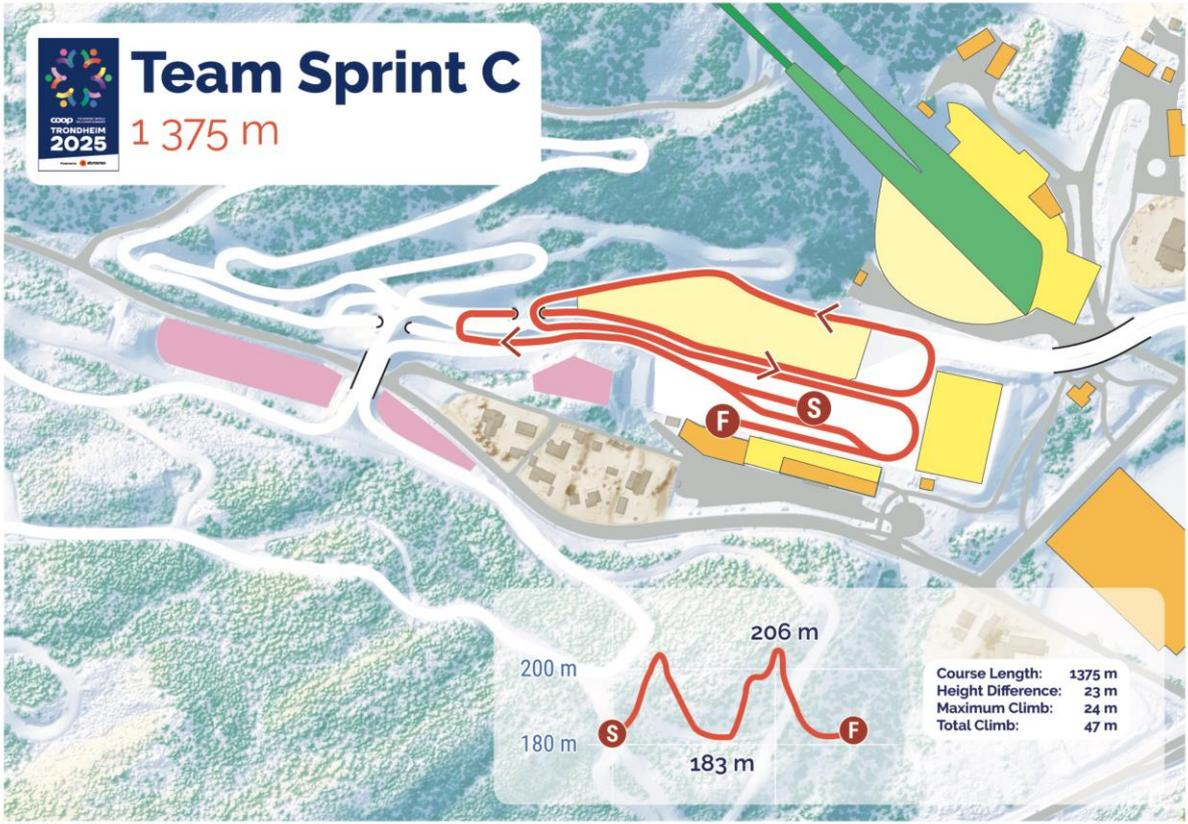
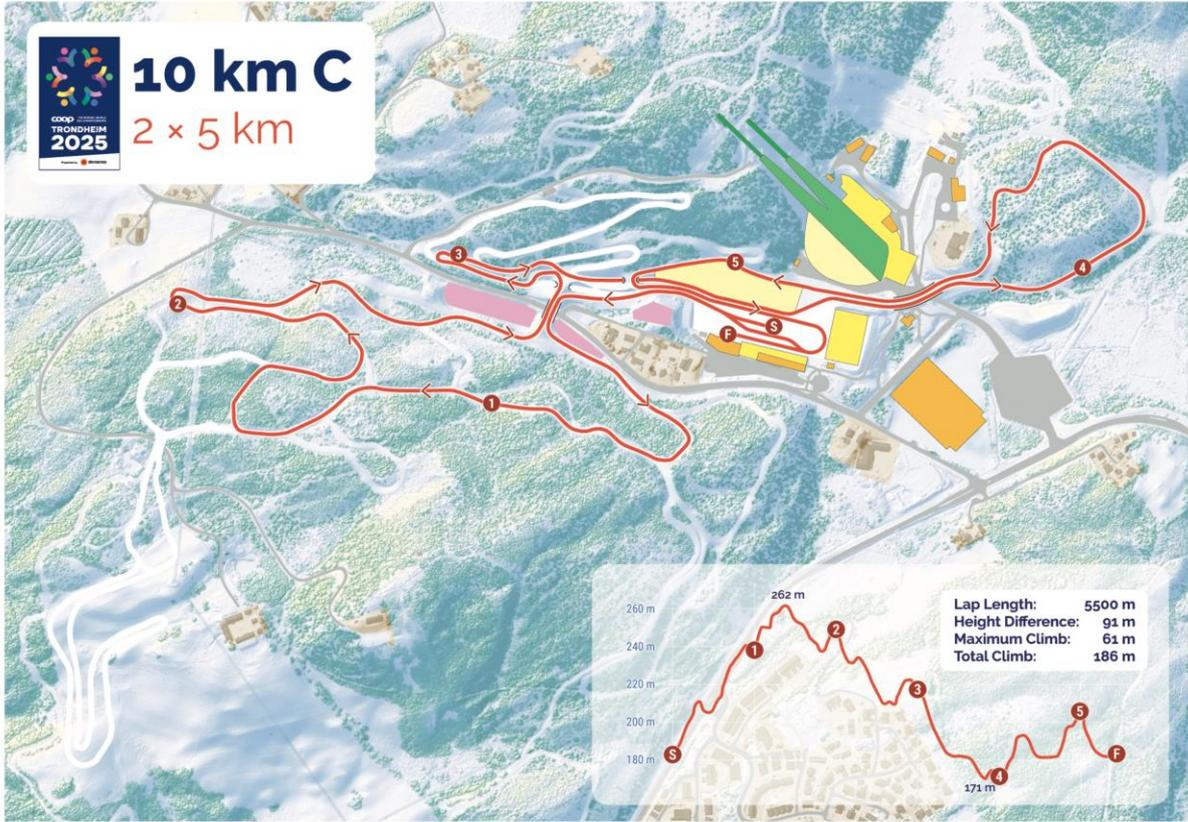



# Relay 4×7,5 km

4×3.75 km C + 4×3.75 km F



Cartography: eMap.as (www.emap.no)



# 50 km F

6 × 8.3 km

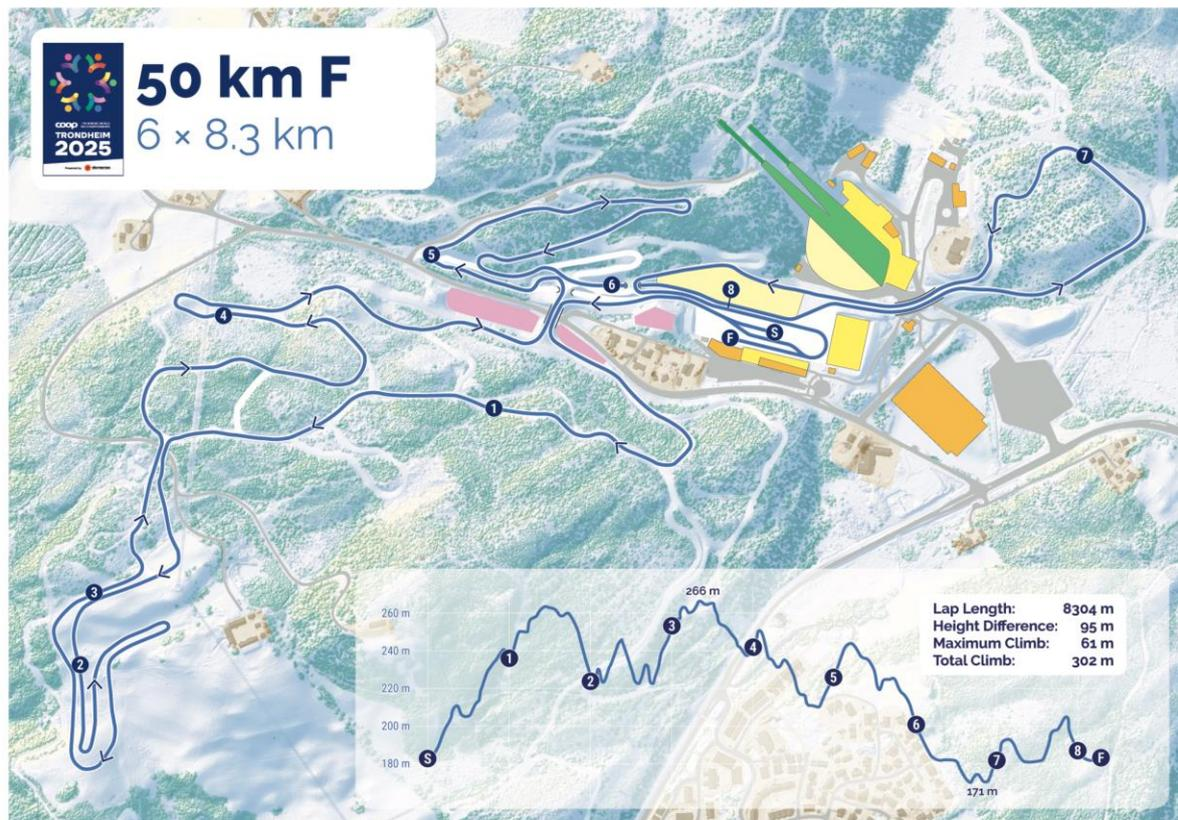

Cartography: eMap.as (www.emap.no)

## 5.3 Nordic Combined Courses'





# NC Compact Men

3 × 2.5 km



Cartography: eMap as ([www.emap.no](http://www.emap.no))



# NC Team Men

4 × 5 km

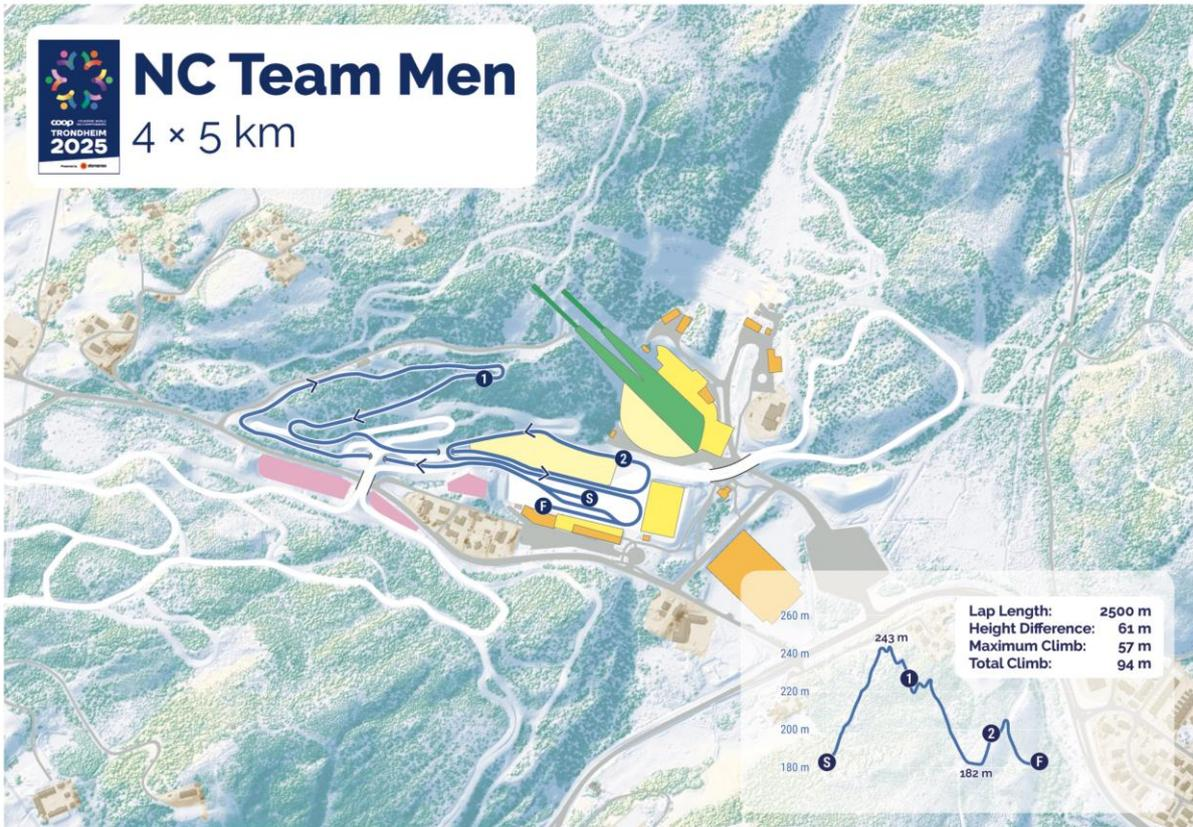

Cartography: eMap as ([www.emap.no](http://www.emap.no))



# NC Gundersen Men

2.5 + 7.5 km

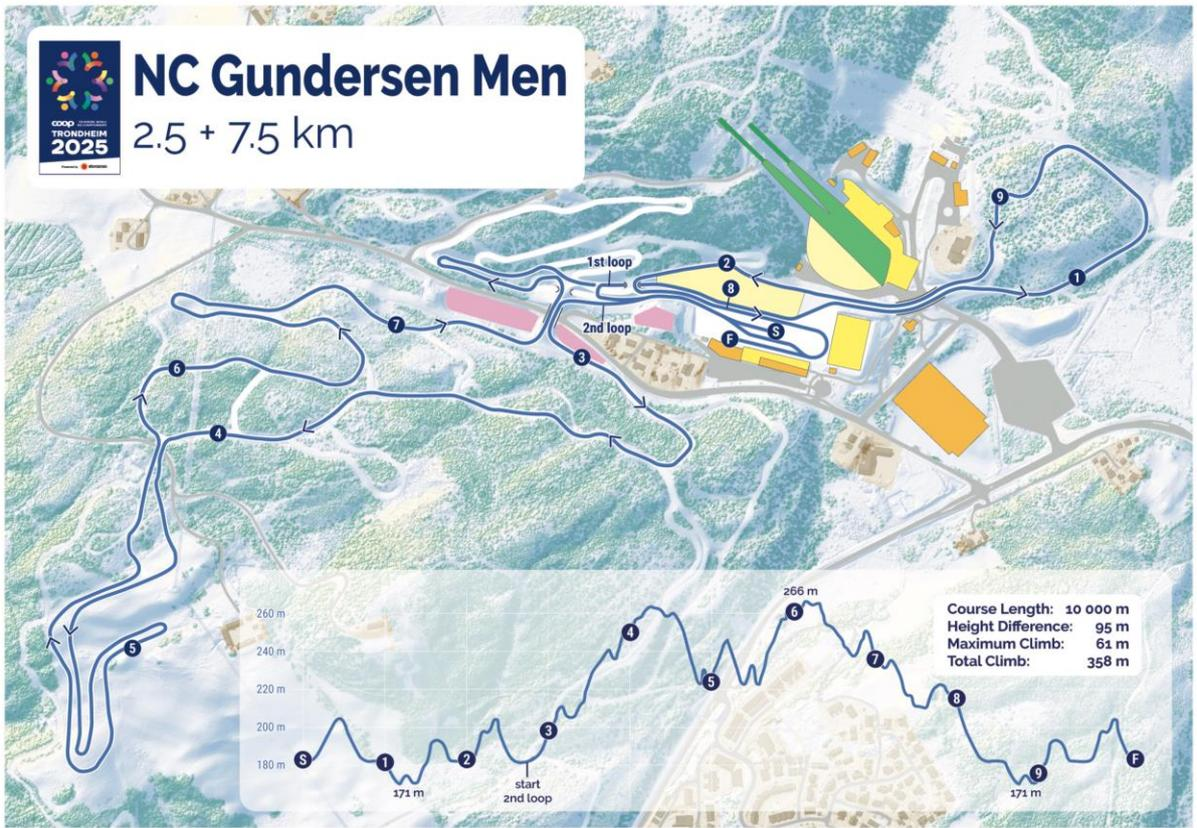

Cartographiv. eMap as (www.emap.no)

## 5.4 Para Cross-Country courses

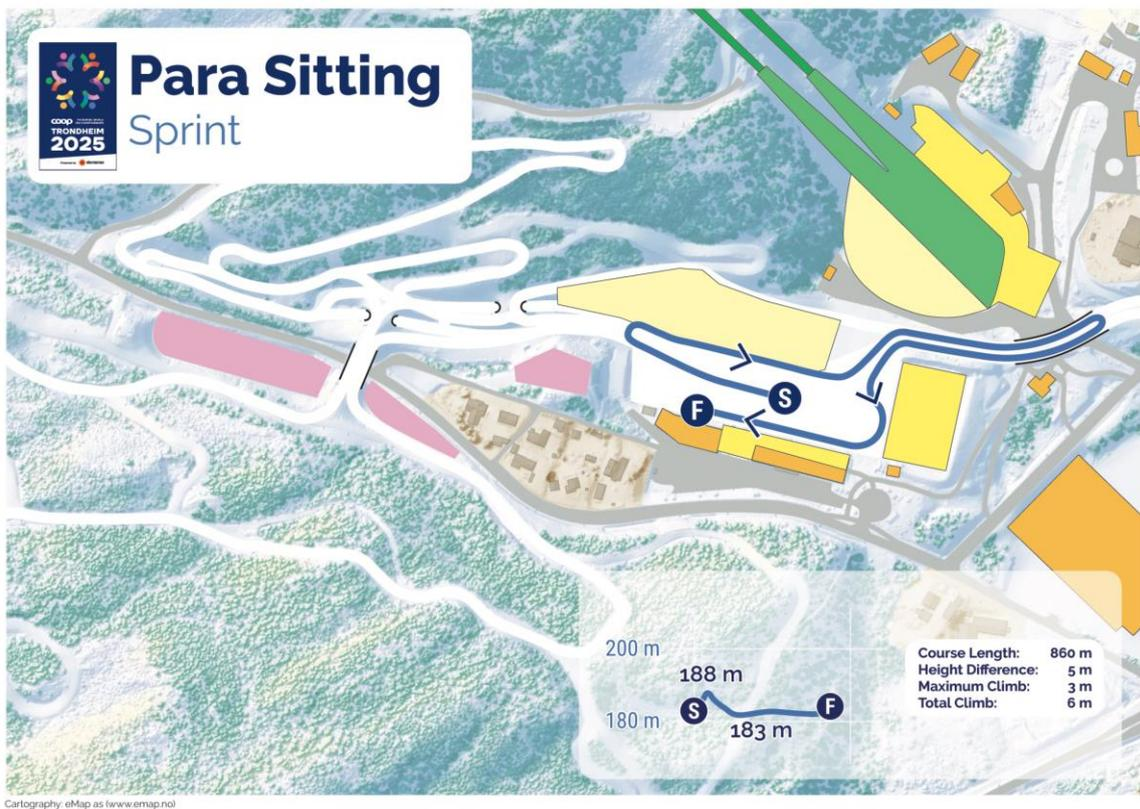
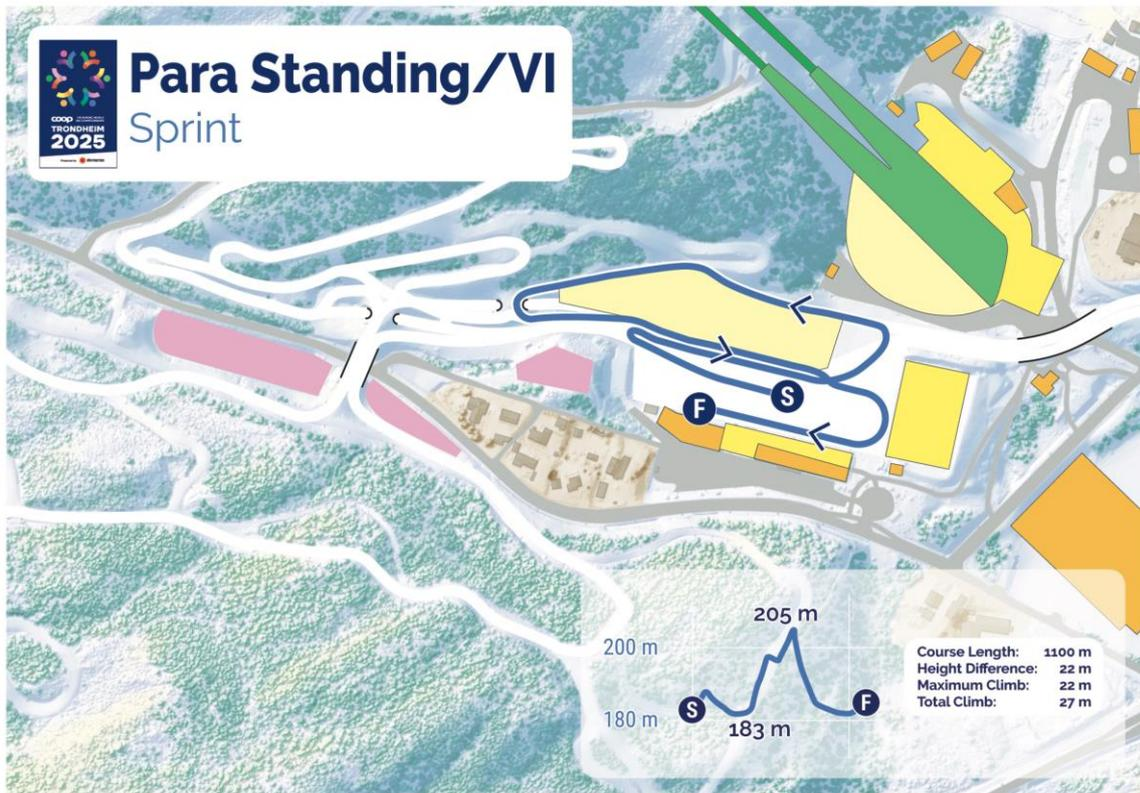

## 5.5 Ski testing areas



It will also be possible to test skies in the stadium area. Details will be set by the jury during the championship.

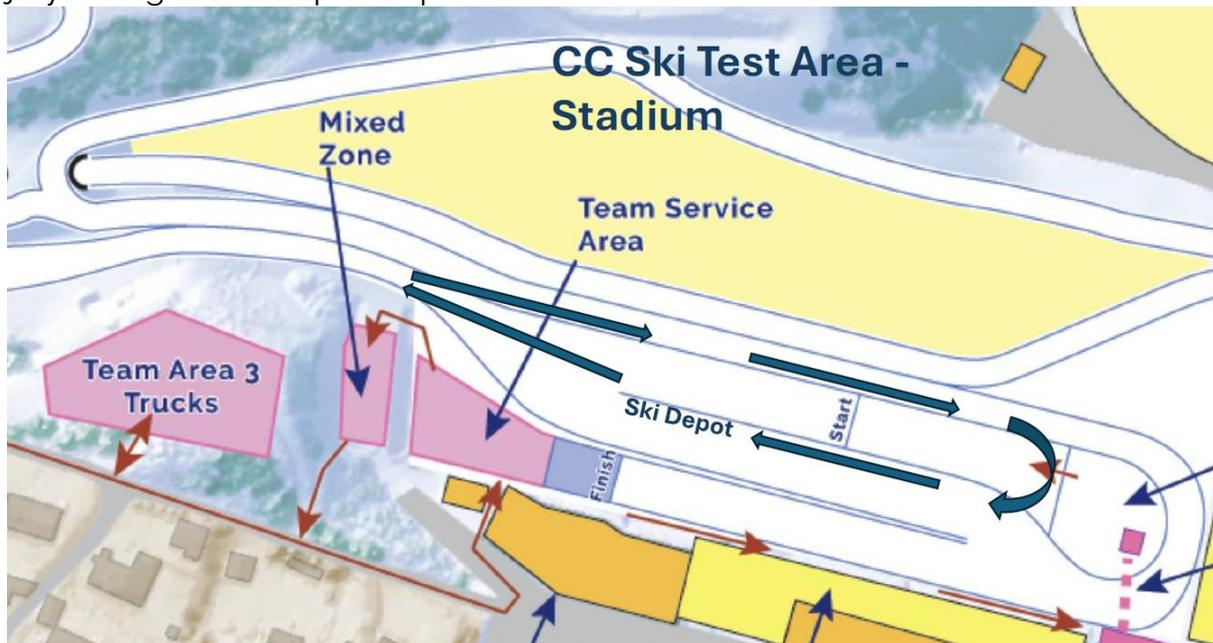

## 5.6 SJ-arena

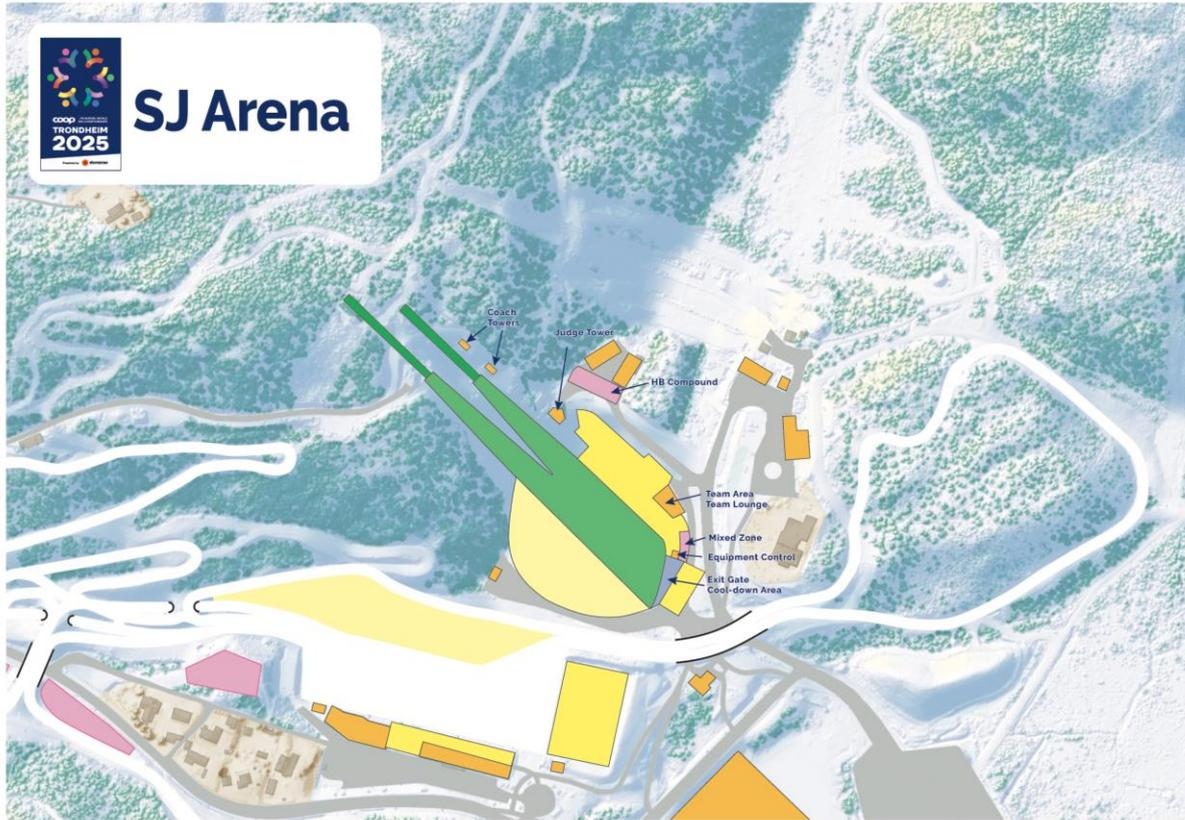

# Hill certificate Normal Hill



No. 290 / NOR 40 **certificate after reconstruction**

## CERTIFICATE OF JUMPING HILL CERTIFICAT DE CONFORMITE SCHANZENPROFILBESTÄTIGUNG

Date of issue 22.12.2023  
Établi le  
Ausgestellt am

Valid till 30.04.2028  
Valable jusqu' au  
Gültig bis

Place: Trondheim

Name: Granåsen

HS = 105 m

$h/n = 0,548$

$V_0 = 24,25$  m/s

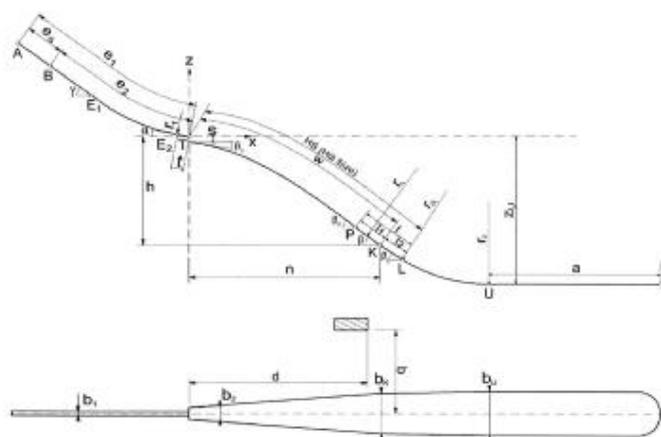

$e_1 = 94,20$ m	$V_0 =$	$P = 82,50$ m
$e_2 = 67,70$ m	$l_1 = 11,50$ m	$K = 94,00$ m
$e_s = 26,50$ m	53 gates à 50cm è 40x39cm $l_2 = 11,00$ m	$L = 105,00$ m
$t = 6,50$ m	$a = 61,52$ m sloping up	$b_1 = 2,50$ m
$s = 2,20$ m	$\beta_D = 36,76^\circ$	$b_2 = 7,50$ m
$\gamma = 35,00^\circ$	$\beta = 33,94^\circ$	$b_K = 18,80$ m
$\alpha = 11,10^\circ$	$\beta_L = 30,71^\circ$	$b_U = 20,70$ m
$r_1 = 95,00$ m	$r_L = 220,00$ m	$d = /$ m
$h = 44,89$ m	$r_{2L} = 125,50$ m	$q = /$ m
$n = 81,90$ m	$r_2 = 98,00$ m	$z_U = 65,93$ m

## Hill certificate Normal Hill



No. 289 / NOR 39 **certificate after reconstruction**  
**CERTIFICATE OF JUMPING HILL**  
**CERTIFICAT DE CONFORMITE**  
**SCHANZENPROFILBESTÄTIGUNG**

Date of issue 22.12.2023 Valid till 30.04.2028  
 Établi le Valable jusqu' au  
 Ausgestellt am Gültig bis

Place: Trondheim Name: Granåsen

HS = 138 m h/n = 0,566 Vo = 26,60 m/s

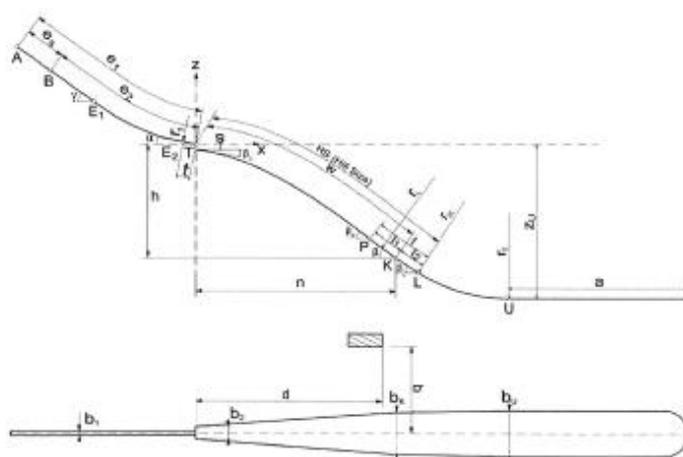

$e_1$	104,90 m	$V_0$	=	$P$	= 104,50 m	
$e_2$	80,90 m	$l_1$	= 19,50 m	$K$	= 124,00 m	
$e_3$	24,00 m	$l_2$	= 14,00 m	$L$	= 138,00 m	
$t$	6,90 m	$a$	= 63,80 m	sloping up	$b_1$	= 2,53 m
$s$	3,00 m	$\beta_p$	= 37,27 °	$b_2$	= 7,50 m	
$\gamma$	35,00 °	$\beta$	= 33,78 °	$b_K$	= 27,80 m	
$\alpha$	11,50 °	$\beta_L$	= 31,37 °	$b_U$	= 27,25 m	
$r_1$	1,60 m	$r_L$	= 320,00 m	$d$	= 77,50 m	
$h$	60,70 m	$r_{2L}$	= 125,50 m	$q$	= 47,00 m	
$n$	107,24 m	$r_2$	= 98,00 m	$z_U$	= 84,06 m	

### 5.7 Lift access and opening times

During training and competition, priority access is given to the competitors, coaches, team personnel and officials on all lifts serving the respective runs. Follow the signs.

## 6. FIS World Championships Rules

### 8 Qualification Regulations

8.1 The eligibility for participation at the FIS World Championships and age groups are defined in the ICR.

8.2 The reigning FIS World Champions have the right to participate at the next FIS World Championships in the events they won, in addition to the team quota, under the condition they are entered by the same National Association (this is valid only for the individual competitions and not for the team competitions). If, however, the World Champions are also entered for other events, they must be included within the overall team quota.

8.3 The maximum number of athletes at each medal event shall be no more than 4 per National Ski Association plus the competitors according to art. 8.2. This rule does not apply to Para Snow Sports events.

8.4 The qualification criteria and the maximum number of athletes per nation at the qualification competitions and official trainings shall be as follows:

#### 8.6 Nordic Disciplines

##### 8.6.1 Cross-Country Events

###### **Qualification competitions and official trainings:**

12 athletes per gender plus the competitors according to art. 8.2.

###### **Minimum requirements:**

To be eligible for entry in the FIS World Championships the cross-country competitors must have 800 FIS points and less in the last FIS points list (distance or sprint) as published before the deadline for the provisional team selection.

Competitors who have 150 Distance FIS points and less on the last FIS points list published before the start of the FIS World Championships will be allowed to start in the distance competitions (Interval Start, Skiathlon and Mass Start).

A qualification competition will be scheduled for the athletes who did not meet these requirements. The athletes who have reached the above requirements are not allowed to start in the qualification race. The top 10 ranked competitors will be allowed to start in the Interval Start competitions as part of their nation's quota. The top 10 ranked competitors will be allowed to start in the Skiathlon and Mass Start competitions as part of their nation's quota under the condition that they have fewer than 200 FIS Distance points in the current FIS Distance points list.

## 8.6.2 Ski Jumping Events

### Official Trainings:

6 men and 5 women including the competitors according to art. 8.2.

### Qualification:

4 athletes per gender plus the competitors according to art. 8.2.

## 8.6.3 Nordic Combined

### Events Qualification competitions and Official Trainings:

6 men and 5 women including the competitors according to art. 8.2.

## 8.11 Table overview of the art. 8.

Should there be any conflict between the art. 8.1-8.10 above and the table under 8.10, the provisions of art. 8.1-8.10 shall take precedence.

Discipline	Max. number of athletes per nation at the qualification competitions	Max. number of athletes per nation at each medal event
Cross Country	12 per gender + reigning World Champion in respective events	4 per gender + reigning World Champion in respective events
Nordic Combined	6 Men and 5 Women	4 per gender + reigning World Champion in respective events Official Training: 6 men and 5 women
Ski Jumping	4 per gender + reigning World Champion in respective events	4 per gender + reigning World Champion in respective events Official Training: 6 men and 5 women
Para Snow Sports	Individual qualification criteria apply and are published on the FIS website.	

## 9 NSA Officials' Numbers

9.1 The maximum number of team officials, medical and technical personnel per national team shall be:

### 9.1.1 Nordic Championships

Number of officials per discipline and gender (based on the final entry):

Cross-Country Women, Cross-Country Men, Ski Jumping Women, Ski Jumping Men, Nordic Combined Women, Nordic Combined Men = number of athlete(s) + 2  
Team Officials (maximum number of participants according to art. 8.6.1–8.6.3)

Number of starting competitors (per discipline and gender)	Number of officials
1	3
2	4
3	5
4	6
etc	etc
12	14

9.1.5 NSA President and Secretary General may be registered by each NSA with the team entry for each of the disciplines. Their registration does not count as part of the total quota.

9.1.7 Extra officials and special guests' numbers (per gender and discipline)

Competitors	Extra officials	Special guests
<3	3	3
4-5	4	4
6-14	5	5
15>	6 (Nordic disciplines)	-

The LOC does not assume any responsibility for organizing accommodation or meals for additional officials.

## 7. Organizational Information

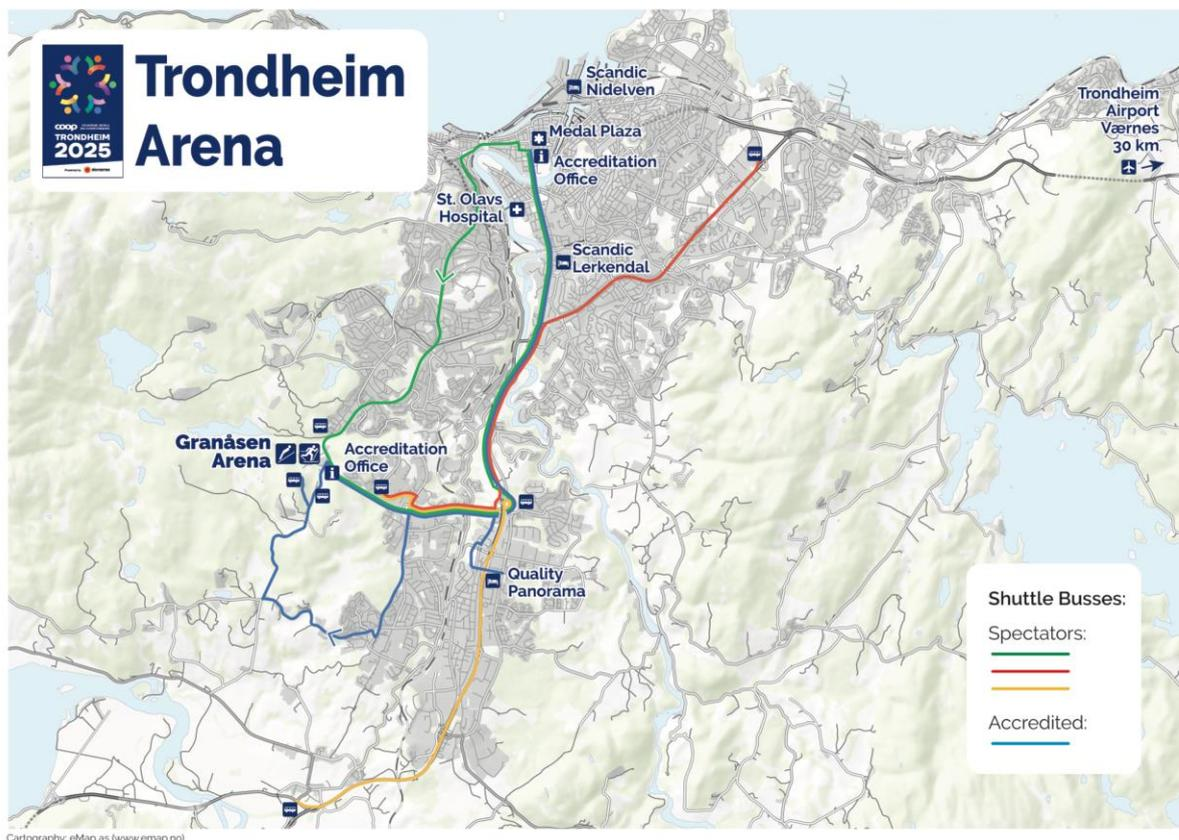

### 7.1 Accommodation and Meals

#### 7.1.1 Accommodation

Hotel	Main group	Distance to Granåsen arena	Distance to Medal Plaza
Scandic Lerkendal*	Team hotel	15 km	2,5 km
Quality Panorama*	Team hotel	12 km	9 km
Scandic Nidelven	Official FIS hotel	11 km	1 km

\*Only for accredited persons

At the team hotels, social areas are arranged for the athletes, and physiotherapy rooms, sewing rooms, drying rooms, meeting rooms, and other rooms are available as needed. The hotels have also rooms adapted for wheelchair users.

## 7.1.2 FIS World Championship Rules overview

### Price per person

Category cost	Per night	Included
Qualified athletes*	0 CHF	Full Board
Non-qualified athletes (13.1)	120 CHF	Full Board
Team officials (13.1)	120 CHF	Full Board
NSA President and Secretary General (13.1)	120 CHF	Full Board
Extra Officials (13.2)	200 CHF	Half Board
Special Guests (13.2)	200 CHF	Half Board

*\*Free accommodation is non-transferable*

### Single rooms

13.3 Single rooms per NSA are provided according to the following table:

1 to 3 officials	1 single room
4 to 6 officials	2 single rooms
7 officials or more	3 single rooms

For any extra single room including qualified athletes, if available, the LOC will charge 200 CHF per night (250 CHF per night for extra officials and special guests).

Accommodation needs for para-athletes for the period March 3<sup>rd</sup> – March 6<sup>th</sup> 2025, need to be registered in a separate registration form. The form will be available on the FIS Para Cross-Country Calendar Page.

Latest by 31<sup>st</sup> of October 2024 the number of double and single rooms requested, incl. accessible rooms and arrival/departure dates, must be communicated to the LOC (please see article 12.3). After receiving the preliminary entry, the LOC will send feedback to the NSA regarding the reservation. Allocation of extra rooms will be handled on a "first come first served" basis within available capacity.

When LOC has received the preliminary entry, the NSA will receive ongoing confirmation of details and feedback about the designated hotel, and no later than 15<sup>th</sup> of November 2024.

The LOC will not be responsible for teams that wish to take care of their own accommodation arrangements. Arranging accommodation outside of the LOC system is the sole responsibility of the NSA. As such, the NSA are responsible for transport, meals etc.

The LOC covers the cost of accommodation for qualified athletes according to rules in article 13.10. The rate will be at maximum price 120 CHF/person/night. Receipt must be presented.

Member companies of SRS must register through the FIS online system. In cooperation with the SRS Association, accreditation for the team hotels will be assigned. The cost for SRS accommodation will be 120 CHF per night.

### **Team payment deadlines and terms**

LOC will invoice the NSA based on the reservation made in preliminary entry and final entry according to the following dates:

<b>Invoice sent out</b>	<b>Payment due</b>	<b>Amount due</b>
1 <sup>st</sup> November 2024	21 <sup>st</sup> November 2024	50% of total
6 <sup>th</sup> February 2025	21 <sup>st</sup> February 2025	40% of total
At departure	1 <sup>st</sup> April 2025	10% of total + extra

Outstanding accommodation and remaining/extra costs to be paid by card at the financial office or invoiced.

If payment is not received before the due date, the LOC reserves the right to cancel the reservation.

Before 5<sup>th</sup> February 2025 (12.4.1 Provisional team selection), a National Ski Association can change their accommodation reservation by a maximum of 20% of the total nights without payment of a penalty as per art. 13.4. (additional requirements are subject to availability).

Reimbursement of the expenses according to the rules for free accommodation for qualified competitors will be paid as soon as possible but no later than 1<sup>st</sup> of April 2025.

### **Cancellation conditions**

Cancellations must be made via the FIS online entry system, and via email [accommodation@trondheim2025.no](mailto:accommodation@trondheim2025.no) for Para Cross-Country.

Cancellation may be done without charge, in case of:

- Cancellation of up to 100% of the original reservation is received before 31<sup>st</sup> of October 2024.
- Cancellation of up to 50% of the original reservation is received before 30<sup>th</sup> of November 2024.
- Cancellation of up to 20% of the original reservation is received before 5<sup>th</sup> of February 2025.

Booking details received by 5<sup>th</sup> of February 2025 will be considered as final and will be the basics for calculating the total payment, cancellation fees and charges for no-shows. In case of no-shows there will be no refund (100% of the booked reservation has to be paid). If a cancellation is received later than the above-mentioned dates, the NSA must pay 100% of the reservation.

### **7.1.3 Meals arrangements**

Breakfast, lunch and dinner will be provided at the team hotel.

At the venue, warm lunch will be available in the team hospitality area\*. The warm lunch will be served at specified times, and it will also be available coffee/tea, water, snacks and fruit.

The meals both at the hotel and in the team hospitality will correspond to the needs of highly competitive athletes and in line with FIS guidelines, in addition according to the recommendation from the Norwegian Olympic Top Sports Centre.

Team hospitality will have a chill area for athletes to relax and to prepare for competitions.

*\*Location for team hospitality is marked in arena map under sections 5.2 CC-arena and 5.7 SJ-arena.*

## **7.2 Transport and parking**

### **7.2.1 Transportation**

Transportation from the official airport, Værnes Airport, will be provided free of charge to the teams. The free service includes one trip per team per discipline in each direction. Please let us know how many bags and ski bags (SJ and CC ski bags) your team brings in order to organize an appropriate vehicle.

The LOC will provide a shuttle bus service between the team hotels and the venue, free of charge, that is tailored to the needs of athletes and service personnel to and from the arenas.

For independently booked accommodation, the transportation to the venue and back will be provided only for an extra cost. Request needs to be sent to [transport@trondheim2025.no](mailto:transport@trondheim2025.no) not later than 31<sup>st</sup> of January 2025.

There will also be LOC-cars that can be ordered by accredited persons if special needs, subject to available capacity.

### **7.2.2 Parking information**

There are limited parking spots at Granåsen arena. If the teams bring their own cars, it is possible to get drop-off permission with a valid accreditation card for one car per team, but then the car needs to be parked outside the arena/nearby the hotel. For service personnel, the LOC can offer 1-2 parking permissions to each team (depending on the size of the team) in walking distance to the team areas. The parking permissions will be given to the team captains at the accreditation office.

Teams will have parking spots available at the hotel. Nevertheless, they will remain limited. LOC offer 1-2 parking spots per team (depending on the size of the team) in connection to the hotels. If a team have several cars, they must pay a fee for the additional ones. We kindly ask all teams to come with as few vehicles as possible to avoid any parking difficulties as well as to adopt an approach of corporate social responsibility.

More detailed information will be sent together with the team guide.

### **7.2.3 Venue access information**

The main roads around the venues, both in Granåsen and city square, will be closed throughout the whole event. Valid accreditation card must be used to enter the venue.

## **7.3 Team Captains Meeting**

See cap. 5.1

## 7.4 Wax Cabins and wax trucks for teams and SRS Industry

### Cross-country team area

Wax cabins are located in Team area 1 as described in the CC venue map. There will be cabins of two or three heights in rows of 8. Every cabin will be supplied with one table, two chairs, heating, lighting, ventilation and wireless internet.

The LOC together with FIS will make the final allocation after receipt of the preliminary entries. Wax cabins must be registered by 31<sup>st</sup> of October 2024.

### Prices for additional wax cabins

Single cabin (approx. 6 x 2,4 m) 3000 CHF (excl. VAT)

Double unit (one large space approx. 6 x 4,8 m) 6000 CHF (excl. VAT)

Invoices must be paid until: 1<sup>st</sup> December 2024.

### Wax trucks

At the Granåsen venue one wax vehicle/truck per team with maximum dimension 20 x 10 m (when extended) will have permission to park. Team needs to register their wax vehicle/truck with the by 31<sup>st</sup> of October 2024 via the FIS Online Registration System. All wax vehicles/trucks will be allocated at the Cross-Country team area. Teams arriving with wax trucks are not entitled to a wax cabin. There will be no space for small trailers in addition to the wax truck.

### Grinding trucks and trailers

No grinding trucks or trailers can be parked in the cross-country team area due to limited space. We offer all nations with grinding truck a dedicated parking nearby the team hotels, for rental. Location TBC.

### SRS Industry

Member companies of SRS need to register via the FIS online system. In cooperation with SRS, LOC will confirm wax cabins as well as parking spaces. There will be no space for SRS waxing trucks/trailers. The price for each cabin is 3000 CHF (excl. VAT).

## 7.5 Accreditation and Course Access

### 7.5.1 Accreditation

#### **Art. 9.1.4 Transferable accreditations for Team Officials**

Up to 50% of the above number of team official accreditations may be exchanged during the Championships to accommodate different coaches and support staff in the different events. The accreditation card of the departed official must be returned to the LOC in exchange for a new one. Access passes to the Team and Restricted Areas will be provided to the teams to distribute internally, based on the above quotas.

### Accreditation

The main accreditation office will be nearby the city square. There will also be a sub accreditation center in Granåsen. Information about exact location and opening hours TBC.

The accreditations will be approved according to the registrations in the FIS Entry. The FIS season accreditation will not be valid.

Those who don't register through the FIS online entry system need to apply for accreditation. This includes the Para Cross-Country athletes and teams. You will find the application form and information by using this link : [Accreditation - Ski-VM Trondheim 2025](#) The application form will be active from 15<sup>th</sup> September 2024.

Any questions regarding accreditation please contact [accreditation@trondheim2025.no](mailto:accreditation@trondheim2025.no).

### 7.5.2 Course access

#### **Art. 9.2 Access to the competition courses**

Access to the competition course(s) is defined by the Jury and communicated at the team captain's meetings. Persons granted access to the competition course(s) and restricted areas shall be provided with an additional access card or other agreed identification.

For Para the course bib distribution will be communicated at a later stage.

The bibs will be distributed at the Race Office.

## 7.6 Medical services

### 7.6.1 Hospitals and emergency services

In case of emergency in Norway, call 113

Medical facilities are located in both venues.

Hospital nearby: St. Olavs Hospital: <https://stolav.no/en>

### **7.6.2 Pharmacies**

There are several pharmacies nearby all the official hotels and in the City of Trondheim. The info desk at the hotel will have more detailed information about the specific locations.

### **7.6.3 Doctors' meetings**

The Norwegian Ski federation and LOC in Trondheim invites all medical team personnel from participating countries to a Sports Medicine Seminar Tuesday February 25<sup>th</sup> at 3 to 6 pm at the Scandic Lerkendal Hotel (room Mezzanine).

The seminar will be relevant for both doctors and physiotherapist, and we hope to see as many as possible at this event, the day before the opening ceremony. The seminar program will be announced in more detail in a later communication.

A Team Doctors Meeting will be held at the end of the seminar.

### **7.6.4 Insurance**

All athletes need the insurance arranged by their NSA. LOC is not responsible for any injuries of the athletes neither for the damage or lost property.

## **7.7. Anti-Doping**

Anti-Doping control of all events is compulsory.

The FIS Anti-Doping Rules compiled in accordance with the World Anti-Doping Code define all by-laws concerning anti-doping controls.

The LOC of the FIS World Championships are responsible for the arrangements for the post-competition doping controls. The Anti-Doping Control Station will be situated near to the location where the press conference is taking place in the Venue Granåsen, and with sub-center for Anti-Doping control near to the Medal Plaza.

## **A clean, conscious, and honest championship!**

The FIS Nordic World Ski Championships Trondheim 2025's Anti-Doping work is value-based and a fully integrated part of our organization. The Anti-Doping mission is based on the approach; clean, conscious and honest. Our statement aims to elaborate on the importance of extensive Anti-Doping work with increased knowledge and awareness.

Anti-Doping Norway will provide education activities according to the requirements of WADA's International Standard for Education (ISE) and FIS. The activities will include, among other things:

- Honestly campaign leading up to and during the WSC with clear voices that are committed to clean sport
- Outreach program for athletes and support personnel during the WSC
- Visibility of a clean sports message in the WSC arena

## **7.8 Visa request and information**

Citizens of some countries will need a visa for visiting Norway.

- Norway: <https://www.udi.no/en/>
- Please check with your embassy if you need a visa.

For an official letter of invitation, please send a request to [wctrondheim@trondheim2025.no](mailto:wctrondheim@trondheim2025.no)

## **7.9 FIS Family Tickets**

According to art. 13.10.5 each athlete is entitled to receive free of charge two tickets from the LOC for each competition in which they are competing.

The tickets can be picked up at the ticket cabins nearby the entrance to the arena for spectators.

## **7.10 Other**

### **7.10.1 The use of radios**

The import, export and operation of radio equipment in Norway is regulated by national law. Permits for the use of radio transmission equipment must be requested according to national specifications.

For information please see: <https://www.nkom.no/english/frequency-licences>

Please fill in the form "Application for temporary use of radio equipment in Norway" and return it to: firmapost@nkom.no.

Deadline: as soon as possible.

### **7.10.2 Useful numbers**

- Telephone country code: +47
- Emergency/ambulance: 113
- Police: 112
- Fire department: 110

### **7.10.3 Truck driving**

There is no need for special permissions for truck driving on Norwegian roads. No special rules and regulations, except for the normal Scandinavian weather and snow conditions and the need for snow tires.

### **7.10.4 Press conferences**

A fully equipped Press Conference room will be available at the MMC – Main Media Center – for both national and international use.

## 8 Sustainability

The FIS Nordic World Ski Championships Trondheim 2025 has the ambition to be the most sustainable WSC of all time. When Trondheim again hosts a major championship, we have set ourselves high goals to minimize our environmental impact and be a social and inclusive arena and give a profit back to sport.

The WSC-arena you will be competing in has been built to promote public health and activities in everyday life. The development of the facility has won awards for its work with the environment and recycling. Several of the buildings produce their own energy through solar cells, and the energy we use comes from water and wind power in the region. On the days when there is no world skiing championship, the facility bustles with life with everything from exercisers, meetings for the elderly and children and young people who are physically active with ski games and a recruiting facility for jumping. Granåsen also acts as an entrance portal for miles of ski slopes in the hilly and beautiful Bymarka.

Our sustainability strategy is based on the UN's sustainability goals, and we have chosen to focus on six goals where we can make the biggest difference: good health and quality of life, industry, innovation and infrastructure, less inequality, responsible consumption, and production, stopping climate change and cooperation to reach the goals.

Equality and equal opportunities are a central part of our strategy. We are proud to be the first skiing WC with equal prize money, more equal distances for women and men, and more exercises for women in combined.

In order to achieve our sustainability plan, we have initiated many different measures and projects on the way to the WC. This is everything from the World Cup to a work-inclusive arena, reducing our plastic use and promoting reuse and recycling. We will measure our measures and after the WC we will deliver a full-fledged climate report. Here everyone must report on everyone on our emissions within energy, purchasing, waste, transport and food and drink. The climate account will be used by the next organizer of the WC, Falun 2027, to become even better!

Together we will create the most sustainable Ski WC ever, for winters to come!

### What are we doing?

- **World-class waste management:** World-class waste management: We prioritize reuse and recycling, aiming for 40% material recycling and a maximum of 2% food waste.
- **Eco-friendly transportation:** No parking at Granåsen venue. Spectators from Trondheim city center is encouraged to use shuttle buses, walk, bike, or ski. Spectators from surrounding regions are encouraged to use public

transportation. The LOC has 100 vehicles, the majority of which will be electric.

- **Locally sourced food:** Trøndelag is a renowned culinary region with excellent produce from well-managed agriculture, our fjords, and the mountains. We will serve locally sourced food to hungry attendees at the WSC.
- **Sustainable procurement:** We have created a purchasing list for the entire organization that prioritizes sustainable purchases. The top question is, "Do we really need this?" We recommend renting or leasing instead of buying whenever possible.
- **Packaging:** We will serve hundreds of thousands of meals during the WSC. Packaging is therefore important. We are taking control of packaging in our venues and finding solutions that have the lowest environmental impact and produce the least waste.
- **"PlasticSmart":** We are reducing the use of plastic and aim to eliminate all single-use plastic.
- **Carbon emission:** We will measure everything we do. Falun 2027 and other organizers can use the data and accounting to become even better!
- **Social Sustainability**
- **Equal opportunities:** Equal prize money and equal events for women and men.
- **Public health:** On the road to the WSC, we have engaged the entire region through AktiVM, including children's ski races, WSC trails in the municipalities, and community knitting. AktiVM is based on the ABC framework: Act, Belong, Commit.
- **Work inclusion:** All procurement of goods and services is a new opportunity for inclusion. When we needed to clear the forest around the trails and the new 50 km route, we used Hogst AS. This is social entrepreneurship in practice, recruiting and employing former convicts, giving them jobs, good wages, and pride.

### What can YOU do?

- **Travel Smart:** Choose the most direct flight routes, avoid privat jets, consider bus or train options to Trondheim. In Trondheim: use the athlete's shuttle from the hotel and Granåsen.
- **Reduce, Reuse, Recycle:** Minimize your waste, sort waste correctly. Avoid single-use plastics in all forms.
- **Reduce plastic bags:** Bring your own plastic bottle, bag or rucksack to store clothes and equipment while competing.

- **Save Energy:** Turn off lights and electronics when not in use and unplug chargers when they're not needed.
- **Lead by Example:** Your actions can inspire fans, fellow athletes, and future generations. Use your social media platforms to share your sustainable practices and encourage others to follow suit.
- **Speak Up:** If you see opportunities for improvement, don't hesitate to share your suggestions with us.
- **Together for winters to come!** Let's make this a World Championships where environmental responsibility is a point of pride.